



**ADDITIONAL RULES  
WAKEBOARD &  
WAKESKATE BOAT**

**Revision: 2013-03-21**

## INDEX

1	Appendixes .....	3
2	General .....	3
3	Categories.....	4
4	Running Order & Heat System (Replaced IWWF Wakeboard World Rule 5).....	4
5	Protests (Replaces IWWF Wakeboard World Rule 15).....	5
6	Wakeboard Course .....	6
7	Out-Of-Course Falls (In addition to IWWF Wakeboard World Rule 22.1).....	6
8	Double-Up (Replaces IWWF Wakeboard World Rule 19).....	6
9	Boat Speed & Rope Length (Replaces IWWF Wakeboard World Rule 21).....	7
10	Wakeskate .....	7
11	Homologation .....	8
12	Registration.....	9
13	Officials .....	9
14	E&A Wakeboard Ranking List .....	9
15	E&A Championships .....	9

## **IMPORTANT!**

Please note that from 2013 IWWF Region E&A will be following the IWWF Wakeboard World Rules. Therefore, when reviewing this document it is essential that it is review in conjunction with the IWWF Wakeboard World Rules.

## **1 APPENDIXES**

A number of appendixes are an integral part of these Rules but published and updated as separate documents. These are:

- Rules for Judges
- Heat System
- Ranking Rules
- Pre-Event Homologation Form
- Post-Event Homologation Form

## **2 GENERAL**

### **2.1 Applicability of the Rules**

The IWWF Wakeboard World Rules and these Additional Rules apply to the Europe & Africa Championships and to all other homologated competitions in Europe & Africa, unless varied elsewhere in the Additional Rules.

Where the words "World" or "IWWF" appear in the IWWF Wakeboard World Rules these are to be read as "Europe & Africa". Where the words "Region" or "Regions" or "Confederation" or "Confederations" appear these are to be read as "Federation" or "Federations".

These IWWF E&A Additional Rules Wakeboard & Wakeskate Boat are supplementary to the general IWWF E&A regulations including the Bye-Laws, Rules of Eligibility, Anti-Doping Policy, Letter of Agreement and Obligations for Titled Events, and Guidelines. In case of conflict between a regulation in these Additional Rules and a general IWWF E&A regulation, the latter shall apply. The general IWWF E&A regulations are of significance for organizers of, as well as judges and riders at wakeboard events, and must be considered.

### **2.2 Discharge of Liability**

On each national or international event, all competitors, or if the rider is under 18 years of age its parent or team captain, must sign a discharge of liability for the organizer and the host federation in case of accident, material damages, or moral or physical tort, in the domain of the competition. All organizations, federations, persons or institutions involved in the organization of an event who encounter an illicit deed of a competitor, are obligated to use the local Constabulary or judicial authorities in order to judge all litigations and charges against the competitor. A copy of the filed report shall be forwarded to his own federation who will prohibit the competitor's access to all events as long as the litigations are not definitely settled.

### **2.3 Suggestions**

Riders are encouraged to bring up suggestions and questions of their concern to any judge or to the IWWF E&A Wakeboard Boat Council in any way possible. Contact information to officials and members of the Council is available on the Council's website at [www.wakeboardcouncil.com](http://www.wakeboardcouncil.com). Suggestions regarding these rules must be brought up before November 1st for changes of the rules for the following year.

## **2.4 Extreme Weather Conditions (Replaces second paragraph of the IWWF Wakeboard World Rule 23.0)**

In case of extreme weather conditions the Chief Judge with the approval of the majority of the judges can decide to cancel part or all of the competition and decide a best option on how to define the final placement of the riders, either by completing the competition on an alternative date or location, or based on the completed rounds.

# **3 CATEGORIES**

## **3.1 Minimum Number of Riders (Replaces IWWF Wakeboard World Rule 4.2)**

There will be a minimum of 4 riders required to open a category. What categories that will be opened will only be determined after the end of registration.

A rider will only be allowed to enter one category, either the appropriate age-group category or a higher level of difficulty category than his/her own age-group category, according to the World Rule 4.6, unless the rider participates in both wakeboard and wakeskate, where the rider will only be allowed to participate in one category for each sport (wakeboard/wakeskate). If a rider participates in both wakeboard and wakeskate, the rider will have to pay for both entry fees.

The Chief Judge will ensure that all riders' passports are checked for verification of age.

## **3.2 Youngsters (Boys & Girls)**

This category is for promotional purposes only and will not be counted for towards team scoring, ranking or titles.

9 years old and under - if you are 9 years or under on January 1 in the current year the championships are held.

# **4 RUNNING ORDER & HEAT SYSTEM (REPLACED IWWF WAKEBOARD WORLD RULE 5)**

## **4.1 General**

Competitions will use a heat system. The heat system to be used at competitions is an integrated part of these rules and is published by the IWWF E&A Wakeboard Boat Council as an addendum. This heat system differs from the one used at the World Championships and referred to in the IWWF Wakeboard World Rules.

## **4.2 Qualification Rounds**

In qualifying rounds, the running order will be determined by the latest updated E&A Wakeboard Boat Ranking. The riders tied in the ranking will be randomly selected for the respective positions in the running order. All the riders not seeded by the ranking will be randomly seeded by numbered ping pong balls or by a similar system and added after the ranking seeded riders. The number of riders in each heat is dependent on the total number of riders entered. A percentage of the riders from each heat will then go through to the semi-finals and finals.

### 4.3 If Previous Rider Is Disqualified

In the case where a rider is not available or has been disqualified, a one-minute delay shall be granted to the next rider in the starting order if he was not on the starting jetty at the time of disqualification. If more than one rider has been disqualified, the time allotted to the next rider shall be one minute for each rider disqualified.

Simplified examples:

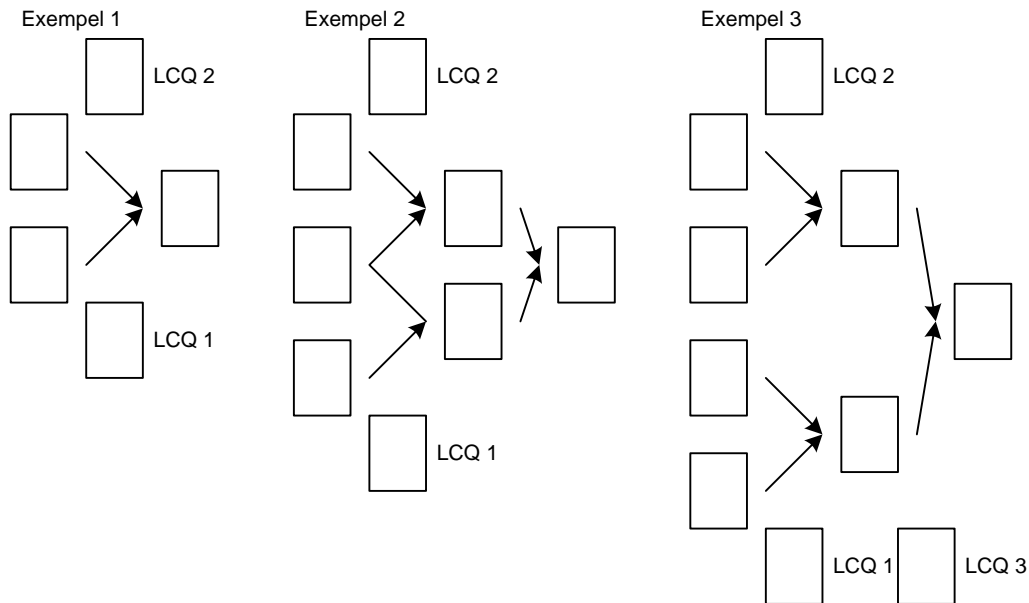

## 5 PROTESTS (REPLACES IWWF WAKEBOARD WORLD RULE 15)

Protests shall be made to the Chief Judge only by a team representative. Protest must be made in writing, must state the reason(s) for the protest, and must be filed as soon as possible, but no later than 10 minutes after the occurrence or after the results of the event are announced in case the protest is regarding the results.

Protests shall be allowed only for failure of the judges and calculators to comply with these rules and only if this non-compliance with rules have an adverse effect on a rider. No protests shall ever be permitted regarding the scoring by the Boat Judges.

A correction of an error in the computation of scores shall not be considered a protest and the correction shall be made on the approval of the Chief Judge and Calculator within 10 minutes after the results are announced. It is up to the Chief Judge only to agree the inspection of scoring sheets

Protests must be accompanied by the approximate equivalent in local currency of 50 Euros - This amount will be refunded if the protest is considered reasonable or upheld by the Judges.

## 6 WAKEBOARD COURSE

### 6.1 Course Dimensions - Without Obstacles (Replaces IWWF Wakeboard World Rule 18.2)

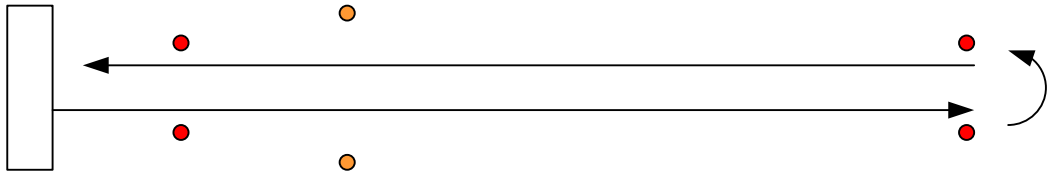

A pair of start buoys 10 meters apart shall establish the approximate area of the beginning of the wakeboard course from each direction. The end of the pass shall be signified by another pair of buoys 10 metres apart. The distance from the start and end buoys, will be approximately 370 metres (38 seconds at 35 km/hour or 22 miles/hour). These course dimensions will be used where practical. Bright orange buoys are recommended for the start and end buoys. A rider's first and second pass will begin after he or she rides around either the right or left hand start buoy. The affected pass will not be scored if the rider does not ride around the start buoy before his or her first or second pass.

### 6.2 Course Dimensions - With Obstacles (Replaces IWWF Wakeboard World Rule 18.2)

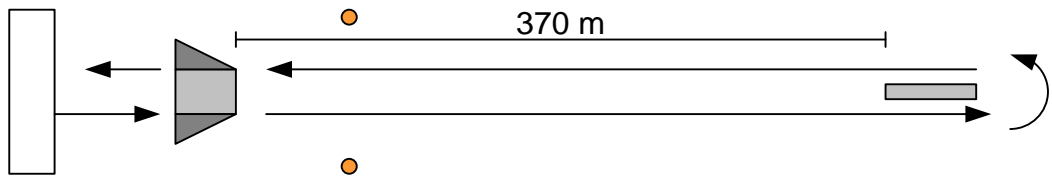

The end of an obstacle shall establish the approximate area of the beginning of the wakeboard course from each direction. The end of the pass shall be signified by the beginning of another obstacle. The distance between the start and end obstacles, will be approximately 370 metres (38 seconds at 35 km/hour or 22 miles/hour). These course dimensions will be used where practical.

### 6.3 Cut-Off Buoys (Replaces IWWF Wakeboard World Rule 18.3)

A pair of cut off buoys, approximately 50 metres apart, will indicate the point after which the tow boat will not be able to get up to speed for a rider to continue his run in the second pass. Bright green buoys will be used for the cut off buoy. The position of the cut off buoys will be determined by the Chief Judge and Chief Boat Driver.

## 7 OUT-OF-COURSE FALLS (IN ADDITION TO IWWF WAKEBOARD WORLD RULE 22.1)

In case of an out-of-course fall or handle throw before the start of a rider's first pass the boat will start again from the jetty.

## 8 DOUBLE-UP (REPLACES IWWF WAKEBOARD WORLD RULE 19)

By a majority of the judges the double-up for one or more categories may be cancelled completely if this should jeopardize the safety or the efficient running of the event.

Each rider who qualifies for the wakeboard finals will be given a double-up. It is the sole responsibility of each competitor to communicate to the driver before leaving the jetty whether he or she would like a left or right double-up. Wakeskate riders will not

have a double-up. Re-rides will not be granted due to any miscommunication between the rider and driver. In the event that the boat provides a double-up in an incorrect direction, the rider must wave off the double-up and not attempt any maneuver. If any maneuver is attempted, which includes cutting at the wake, the rider will be deemed to have accepted his or her double up. If a rider waves off the double-up, the boat will then turn around, and proceed with a double-up in the correct direction. Re-rides will not be granted for turbulent water in this instance. However, if through driver error, then a 3 minute delay will be granted to the rider, to allow the water to calm back to suitable conditions.

In the final, if a rider's first fall occurs beyond the cut-off (3/4) buoys, the rider will have a double-up, but the rider will not be allowed to hit the obstacle at the end of the course, if any, for safety reasons.

An unsuccessful double-up will not affect the score of a rider's routine. But a successful double-up will be counted as a bonus and will add to the rider's score.

## **9 BOAT SPEED & ROPE LENGTH (REPLACES IWWF WAKEBOARD WORLD RULE 21)**

Each rider shall receive his choice of a constant speed through the course for each pass, and preferred rope length. The boat speed, assuming it is held constant before entering the course, is the rider's responsibility. The rider is allowed to adjust the speed of the boat during the routine. The driver shall adjust the speed as quickly as possible after getting notice of the rider's sign.

The rider shall use the standardized signals and not cause the boat to stop, if possible. Deliberate use of delaying tactics will be considered unsportsmanlike conduct and will subject the rider to penalty or disqualification. The following signals apply in addition to well-known riding signals. Use in combination as applicable.

1. Thumb(s) up means go faster
2. Thumb(s) down means go slower
3. Pointing at an item of equipment means a problem with it
4. Pointing back toward object means debris in water
5. Raising hand overhead means request for re-ride
6. Fallen rider must signal to tow boat and safety boat that he/she is OK and/or injured.

It is the responsibility of the Rider to clearly communicating to the Officials in the boat or jetty marshal what rope length he or she desires. It may prove useful for the smooth running of the competition marking the correct rope length with a piece of tape or similar.

## **10 WAKESKATE**

### **10.1 Judging of a Wakeskate Routine**

The judging of the routine begins as soon as the rider leaves the jetty and will end when the rider exits the course or falls for a third time.

### **10.2 Falls**

Either obstacles are used or not, a rider may have a maximum of three falls during a routine, including a fall during an attempted trick during a jetty start.

Should a fall occur, the boat will pick up the rider to proceed with the routine.

The rider will not be picked up after a third fall, or after a fall that occurs beyond the cut-off  $\frac{3}{4}$ -buoy in the second pass.

## **11 HOMOLOGATION**

### **11.1 General**

A competition is homologated through the following steps:

1. A pre-homologation dossier is sent to the IWWF E&A Wakeboard Boat Council in the appropriate format available at [www.wakeboardcouncil.com](http://www.wakeboardcouncil.com)
2. The competition is announced to and sanctioned by the IWWF E&A Wakeboard Boat Council.
3. The competition is put on the official calendar at [www.wakeboardcouncil.com](http://www.wakeboardcouncil.com).
4. The competition is run in accordance with these rules.
5. A homologation dossier, complete results for all heats, including qualification rounds, and a list of all participating riders including date of birth and nationality, is sent to the Wakeboard Boat Council as soon as possible after the completion of the competition, in the appropriate format available at [www.wakeboardcouncil.com](http://www.wakeboardcouncil.com). This dossier should be sent no later than 30 days after the end of the competition.

There is a guideline available at [www.wakeboardcouncil.com](http://www.wakeboardcouncil.com) on how to homologate events that should be followed.

Results from all homologated competitions will be included in the official IWWF E&A ranking for the same year.

Any sanctioned or homologated event, excluding the National Championships, open to international riders must be homologated as an international event to the IWWF E&A. In the case riders from outside E&A region competed at any E&A countries' National Championships, those riders have to be excluded from the results.

In the case a national federation allows foreign riders to ride at their National Championships all E&A region riders will get their results counted towards the E&A ranking.

In addition, it is up to the Chairman of the Wakeboard Council to find other agreements.

### **11.2 Fees**

Homologation fees for national and international events, as well as the additional fees for cash prize competition shall be applicable in accordance with the IWWF E&A Bye-Laws.

### **11.3 National Competitions and National Championships**

For homologated national competitions there must be 3 judges, all must be recognised by the IWWF E&A Wakeboard Boat Council.

### **11.4 National Championships**

For national championships, at least the Chief Judge must be of International Level 2 standard, and all the other judges recognised by the IWWF E&A Wakeboard Boat Council.

### **11.5 International Events**

If five or more countries are represented at the event at least two of the judges must be of International Level 1 standard, and the rest of at least International Level 2 / National Level 1 standard.



If less than five countries are represented at the event at least one of the judges must be of International Level 1 standard, and one of at least International Level 2 / National Level 1 standard.

### **11.6 E&A Championships**

All judges must be of International Judge (Level 1) standard.

## **12 REGISTRATION**

All competitors must be members of their respective Federation. A competitor must be able to prove his or her membership in his or her National Federation at any homologated event. Prior to competing, a competitor must sign a participation contract and understand the nature of the sport and its special risks, particularly in the format. It is the responsibility of the competitor to register with the designated registration person and show proof of Federation membership before riding. Competitors must disclose to the event organiser any special medical conditions, including but not limited to, injuries in the past or present or other pre-existing medical conditions. A document may be sign by all riders at the registration.

## **13 OFFICIALS**

The minimum number of officials in the panel at a competition is:

- Chief Judge
- 2 Assistant Judges
- Calculator
- Boat Driver
- Jetty Marshall

## **14 E&A WAKEBOARD RANKING LIST**

An IWWF E&A Wakeboard Boat ranking list will be created and results collected from homologated national events and tours, National Championships, international homologated events, the E&A Championships, and the IWWF World Championships. The IWWF E&A Wakeboard Boat Council must receive a homologation dossier together with complete results from each homologated competition.

## **15 E&A CHAMPIONSHIPS**

### **15.1 Entry Requirements for E&A Championships**

#### **15.1.1 Rider Eligibility (In addition to IWWF Wakeboard World Rule 9.1)**

Only riders from Region E&A are eligible to enter the E&A Championships.

#### **15.1.2 Team Entry (Replaces IWWF Wakeboard World Rule 9.2.1 and 11.1 and 11.3)**

A team can comprise a maximum of ten riders, among which a maximum of eight can be wakeboard or wakeskate riders. A maximum of two riders can compete in the same category. The same rider may enter in both wakeboard and wakeskate but will be counted as two team riders. Although it is encouraged to have a mixed participation with men and women riders within a team, it is not compulsory. Federations must nominate their team riders before the specified deadline posted in the first E&A Championships' Bulletin distributed by the host Federation. The best six scores will be taken

for country classification. In case of equality the best seventh score will be used to untie.

## **15.2 Minimum Number of Countries Represented**

To open a category at the E&A Championships, a minimum of 3 different countries need to be represented in that category.

## **15.3 Competition Site During E&A Championships (Replaces IWWF Wakeboard World Rule 2)**

Once the Course has been settled down in accordance with the Chief Judge, (three days prior the event) use of the site is not permitted until the completion of the competition.

There will be no official familiarisation. The organiser, however, has the option to provide paid practice before the start of the competition. If using the official boat and/or course and/or obstacles, it is the responsibility of the organizer to ensure that everything is in order for the start of the competition. The start of the competition may vary depending on the number of entries.

Registration will close at 18:00 two days before the start of the competition. If a rider is not able to be at the site before the registration closes, he/she (or the Team Captain) must ensure that a digital copy of his/her passport is sent to the Chief Judge and Chief Calculator and that his/her entry fee is paid for. As soon as he/she arrives, he/she must go to the Calculation Office with the passport, never later than the first rider of the event starts his run.

## **15.4 Team Rider Replacement (Replaces IWWF Wakeboard World Rule 11.4)**

Should a rider be disqualified for any reason the rider's nation's team will, as a result of this, consist of one rider less. The rider can, thus, not be replaced by another rider.

## **15.5 Team Composition (Replaces IWWF Wakeboard World Rule 10.1)**

The chief calculator shall collect the team composition before the end of the registration, and shall post the team composition before the start of the competition. No protest concerning the team composition will be permitted after the start of the competition.

## **15.6 Officials**

The minimum number of officials in the panel at the E&A Championships:

- Chief Judge
- Assistant Chief Judge
- 5 Wakeboard Judges
- 3 Wakeskate Judges
- Chief Calculator
- Assistant Calculator
- Chief Boat Driver
- Assistant Boat Driver
- Jetty Marshall

## **15.7 Cancellation of part of E&A Championships**

The finals of each category must be completed to determine a winner, even if the Judges are obliged to continue at a different site. If a final cannot be completed, all riders from the event will compete again where and when possible, until a winner is determined.

## **15.8 General Recommendations**

### **15.8.1 Late Entry (Replaces IWWF Wakeboard World Rule 10.2)**

A late entry fee of 10 € per day per competitor shall be levied on each entry not received 10 days before the end of registration.

### **15.8.2 Judges' Clothing**

Official clothes for the officials shall be provided for by the organizer for the prize giving ceremony, opening ceremony, and competition.

### **15.8.3 Bulletin**

Every Bulletin must be approved by the Chairman of the IWWF E&A Wakeboard Boat Council before it is distributed.

### **15.8.4 Transportation**

Transfer from the airport to the official hotel has to be managed by the Organizer. Riders or teams may be charged for the cost of the service, but it must be free of charge for the officials.

Transfer between the official hotel and the competition site has to be managed by the Organizer and has to be free of charge for riders or teams. The Organizer may make a shuttle schedule such as, for example, two transfers in the morning and two transfers in the afternoon.

Renting a car for officials is recommended to the Organizer.

### **15.8.5 Water**

Organisers are obligated to provide fresh drinking water for competitors and officials free of charge.